

Alpine Components

Telephone: 01424 437000 E-mail: info@alpine-components.co.uk
Web: www.alpine-components.co.uk Fax: 01424 722502

PHD-4

Portable Helium Detector

**Model 969-4600
Model 969-4640**

- (I) *MANUALE DI ISTRUZIONI*
- (D) *BEDIENUNGSHANDBUCH*
- (F) *NOTICE DE MODE D'EMPLOI*
- (GB) *INSTRUCTION MANUAL*

PHD-4

Portable Helium Detector





VARIAN
vacuum technologies

Dear Customer,

Thank you for purchasing a VARIAN vacuum product. At VARIAN Vacuum Technologies we make every effort to ensure that you will be satisfied with the product and/or service you have purchased.

As part of our Continuous Improvement effort, we ask that you report to us any problem you may have had with the purchase or operation of our product. On the back side you find a Corrective Action Request form that you may fill out in the first part and return to us.

This form is intended to supplement normal lines of communications and to resolve problems that existing systems are not addressing in an adequate or timely manner.

Upon receipt of your Corrective Action Request we will determine the Root Cause of the problem and take the necessary actions to eliminate it. You will be contacted by one of our employees who will review the problem with you and update you, with the second part of the same form, on our actions.

Your business is very important to us. Please, take the time and let us know how we can improve.

Sincerely,

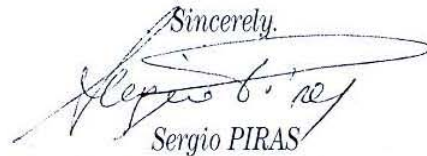

Sergio PIRAS

*Vice President and General Manager
VARIAN Vacuum Technologies*

Note: Fax or mail the Customer Request for Action (see backside page) to VARIAN Vacuum Technologies (Torino) - Quality Assurance or to your nearest VARIAN representative for onward transmission to the same address.

CUSTOMER REQUEST FOR CORRECTIVE / PREVENTIVE / IMPROVEMENT ACTION

TO : VARIAN VACUUM TECHNOLOGIES TORINO - QUALITY ASSURANCE

FAX N° : XXXX - 011 - 9979350

ADDRESS: VARIAN S.p.A. - Via F.lli Varian, 54 - 10040 Leinì (Torino) - Italy

E-MAIL : marco.marzio@varianinc.com

NAME _____	COMPANY _____	FUNCTION _____
ADDRESS : _____ TEL. N° : _____ FAX N° : _____ E-MAIL : _____		
PROBLEM / SUGGESTION : _____ _____ _____ _____		
REFERENCE INFORMATION (model n°, serial n°, ordering information, time to failure after installation, etc.) : _____ _____ _____ DATE _____		

CORRECTIVE ACTION PLAN / ACTUATION (by VARIAN VTT) _____ _____ _____ _____ _____	LOG N° _____
--	--------------

XXXX = Code for dialing Italy from your country (es. 01139 from USA; 00139 from Japan, etc.)



ISTRUZIONI PER L'USO	1
GEBRAUCHSANLEITUNG	5
MODE D'EMPLOI.....	9
INSTRUCTIONS FOR USE.....	13
TECHNICAL INFORMATION	17
DESCRIPTION OF THE PHD-4	17
BASIC UNIT DATA AND SPECIFICATION	19
ROUTINE MAINTENANCE OF THE PHD-4	22
USER INTERFACE	26
ELECTRICAL CONNECTIONS	34
ANALOG INTERFACE DESCRIPTION	34
RS 232 COMMUNICATION DESCRIPTION	36
TROUBLESHOOTING	40
ACCESSORIES AND SPARE PARTS	43

GENERAL INFORMATION

Operators and maintenance staff must be aware of all the risks that may arise when using this instrument. They must be able to recognize hazards and potential conditions of danger and know how to avoid these. Improper and negligent use of the instrument may seriously compromise its efficiency. This product must be used only by qualified personnel. Each operator or qualified person must read the user/maintenance manual carefully and also any other information provided by Varian. "Warning" or Caution" indications must be read and complied with scrupulously. For any problems, contact your nearest Varian office.

The following conventions have been adopted in this manual:



WARNING!

This term is used when failure to comply with the instructions or precautions indicated in the manual may cause injury or death.



CAUTION!

Is used when failure to comply with the instructions may cause damage to the equipment.

NOTES

Information that helps the operator to obtain the best possible performance from the instrument.

STORAGE

The following environmental conditions must be complied with during transportation and storage of the PHD-4:

- temperature: from -20 °C to +70 °C
- relative humidity: 0 - 95% (non condensing)

PREPARATION FOR INSTALLATION

The PHD-4 comes in a special protective packaging; if there are any signs of damage during transportation, contact your local sales office. When unpacking the instrument, take care not to drop the PHD-4 and protect it against impacts.

Do not dispose of the packaging in the environment. The material is completely recyclable and complies with EEC Directive 85/399 on the protection of the environment.



CAUTION!

Never use the PHD-4 and accessory components in a different manner and for different purposes from those illustrated in this manual.

Contents of the packaging

The PHD-4 is available in two different configurations:
1) Model 969-4600 Basic Package that includes:

- Basic unit (5)
- Power supply unit –Battery charger, 100-240 Vac (50/60 Hz) (4)
- Strap (3)
- Cables (2)
- 15-pin counter connector
- Kit of 3 glass wool filters
- CD manual

The above modules are inserted in specific housings in polyurethane foam with density 30. A view of the packaging with the position of the various modules is provided in the figure below.

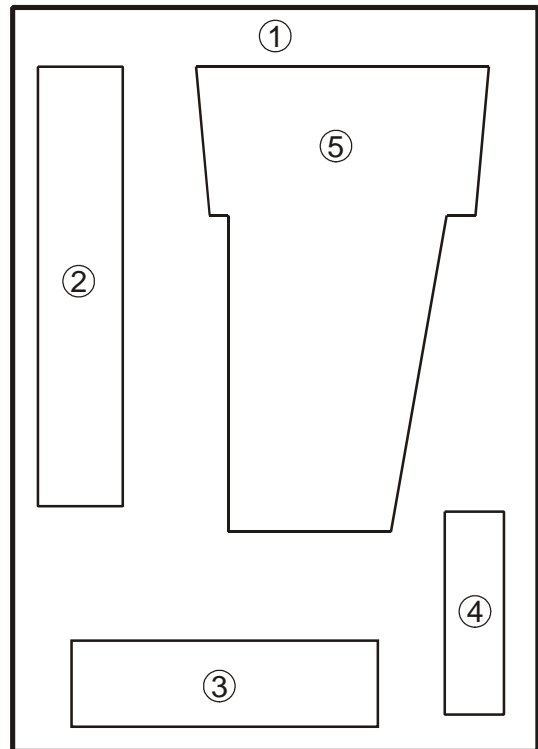

Packaging Model 969-4600

2) Model 969-4640 Complete Package that includes:

- Carrying case (1)
- Basic unit (5)
- Additional battery (1 piece) (9)
- Power supply unit –Battery charger (8)
- Strap (7)
- 15-pin connector for I/O serial-port (3)
- Kit of 5 glass wool filters (4)
- CD manual (6)
- Probe set (10)

The above modules are inserted in specific housings in polyurethane foam with density 30.

A view of the packaging is provided in the figure below.

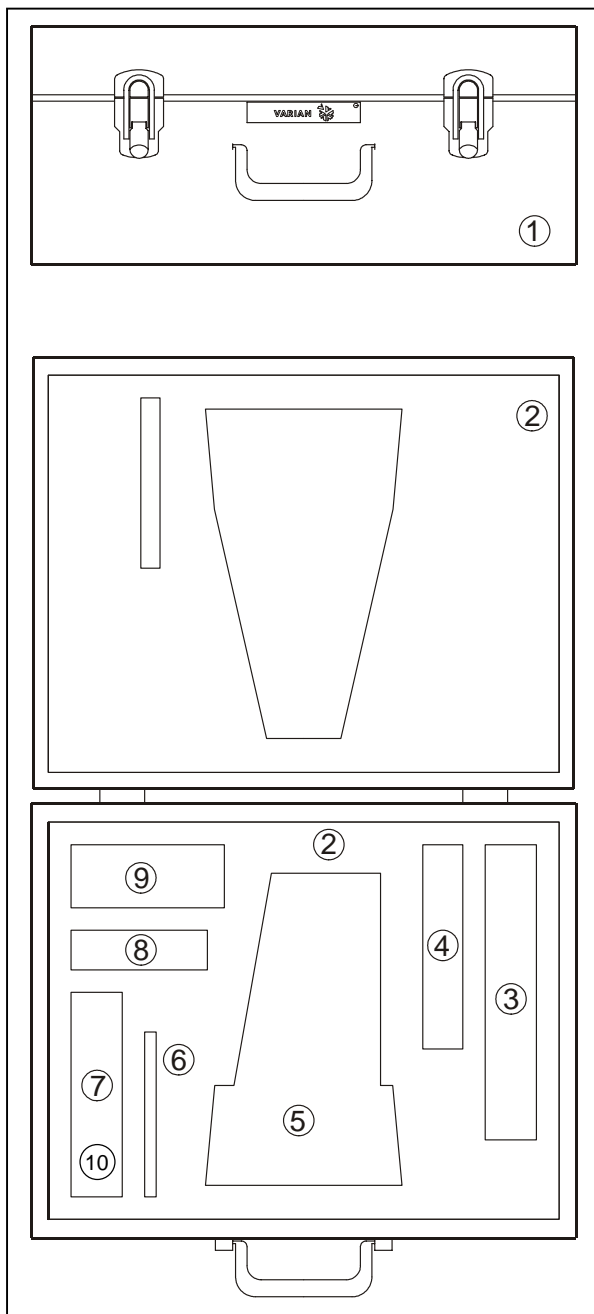

Packaging Model 969-4640

INSTALLATION AND USE



WARNING!

The device is furnished with a battery charger with three-wire power cord with internationally-approved plug. Always use this power cord and insert the plug in an outlet with a suitable protective earthed conductor in order to avoid electrical discharge. High voltages that may cause serious injury or death are generated inside the device.



WARNING!

Do not use the PHD-4 in environments containing potentially flammable gases or vapors. If the PHD-4 is used in combination with sampling safety devices (only if marked EEX ia IIAT4), the PHD-4 must be positioned outside the area with a risk of explosion.



WARNING!

The PHD-4 is complete with a rechargeable battery and related battery charger. Recharge the battery in a safe area far from explosive gases or highly flammable materials. Recharging or use of the device in unsafe areas may cause serious injury and damage.



WARNING!

While the PHD-4 battery pack charging process is running (power supply connected) DO NOT carry the unit.



WARNING!

Use of the device in mines or underground systems is forbidden. Use in an environment not envisaged by the standard may cause serious injury and damage.

The following environmental conditions must be complied with during functions:

- temperature: from +5 to +35 °C;
- relative humidity: 0 - 95% (non condensing).



WARNING!

Do not cover or obstruct the ventilation slots on the top part of the PHD-4 and the rear discharge duct. Obstruction could cause damage to the PHD-4 or to external components.

The PHD-4 does not require maintenance (except for sampling pump, filters and battery).

NOTE

Any operation different from those described in present user manual must be carried out by authorized personnel.



WARNING!

Any unauthorized operation on the device may cause serious injury and damage.

In the case of a fault, contact the Varian repair service or the "Varian advanced exchange service" which makes it possible to obtain a regenerated device as replacement for the faulty unit.

NOTE

Cleaning or decontamination processes are not provided for (see "Health and safety certification box on "Request of return" form)

If a device is to be scrapped, dispose of this in accordance with specific national legislation.

DISPOSAL

Meaning of the "WEEE" logo found in labels

The following symbol is applied in accordance with the EC WEEE (Waste Electrical and Electronic Equipment) Directive.

This symbol (valid only in countries of the European Community) indicates that the product it applies to must NOT be disposed of together with ordinary domestic or industrial waste but must be sent to a differentiated waste collection system.

The end user is therefore invited to contact the supplier of the device, whether the Parent Company or a retailer, to initiate the collection and disposal process after checking the contractual terms and conditions of sale.



Controls and indicators on the front panel of the PHD-4

The figure below shows the front panel of the PHD-4 with the main components.

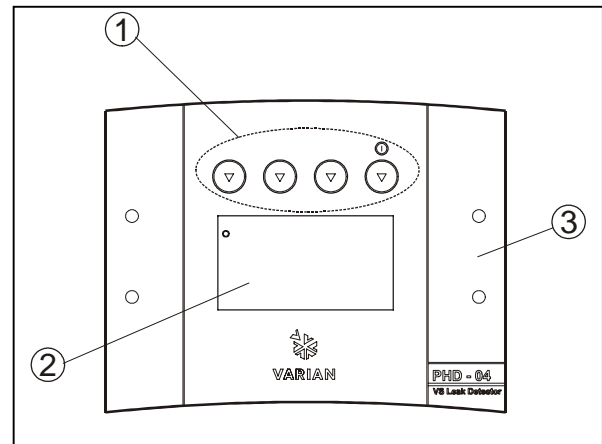

Front panel

1. Function buttons
2. Graphic display
3. Front panel

External Power Supply and Battery Pack

The PHD-4 is a battery-powered portable device. The battery pack can be recharged only and exclusively inside the PHD-4, connecting the Varian SR03.702888 power supply unit to the power supply port 3 (Power Supply connector).

CAUTION!

Never use external power supply units other than the Varian SR03.702888.

Battery charging is fully automatic and starts automatically when the power supply unit is connected to port 3.

CAUTION!

While PHD-4 battery charging process is running avoid to switch OFF and ON again the external power supply. Repeated charging processes can cause battery pack overheating.

The PHD-4 battery can be charged either with the PHD-4 off or during normal functioning.

NOTE

The time required to charge the battery is much longer with the PHD-4 on.

CAUTION!

As Ni-MH batteries are affected by an internal auto-discharging phenomenon a periodical battery charging process is required. Perform a complete battery charging process at least every 3 months and before a stocking period.

The battery pack is protected against shortcuts, overcurrents and overheating by means of a fuse, a recoverable thermal switch and a non recoverable thermal fuse.

The activation of one of these protections is highlighted by the PHD-4 as following described:

- Unit: OFF Power Supply: CONNECTED
The message "No Battery" is showed on the display
- Unit: ON Power Supply: CONNECTED
The battery icon on the main screen appears as a crossed battery
- Unit: OFF Power Supply: NOT CONNECTED
No message on the display – you can't switch the unit ON

If one of the battery pack protections has been activated, switch the unit OFF and disconnect the Power Supply cable, than leave the unit OFF for one hour before connecting the Power Supply again. If the message "No Battery" is showed again, the battery pack have to be exchanged.

Rear panel of the PHD-4

The figure below shows the devices and connectors on the rear panel of the PHD-4.

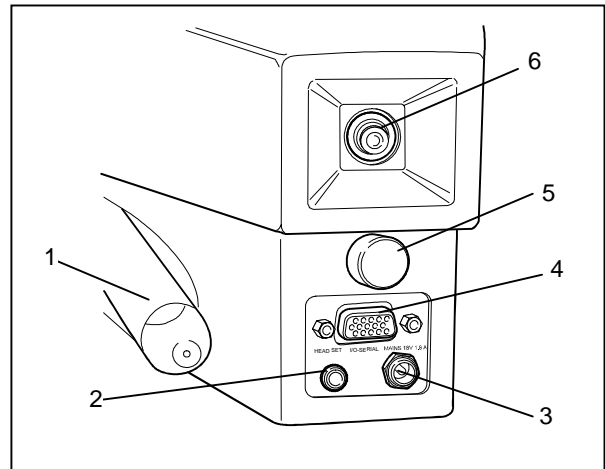

Rear panel

1. Analysis probe
2. Headset connector
3. Power supply connector
4. RS232 I/O connector
5. Fast release device to remove the enclosure
6. Exhaust gas outlet

If charging is performed with the PHD-4 off, the "Battery charge Running ..." message is shown on the display. The "Battery Full" message indicates that the battery is fully charged.

If the battery is charged during normal functioning of the PHD-4, the battery charge status icon highlights progress of the operation with constant increases in level.

Also in the case of charging with the PHD-4 in operation, the "Battery Full" message indicates the end of the charging process.

Connect the Power Supply to a current outlet with the following characteristics:

- V = 90 – 240 Vac
- F = 50 – 60 Hz

NOTE

The power supply plug of the high voltage side must be easily accessible and permit fast, easy disconnection.

NOTE

Main power supply must be provided with protective earthed contact.

DESCRIPTION OF THE PHD-4

The PHD-4 portable leak detector permits fully automatic detection of concentrations of helium down to a lower limit of 2 parts for million (ppm).

The value of the leak is shown in real time on the graphic display on the front panel.

The instrument, which emits an acoustic signal proportional to the concentration of helium detected, incorporates a self-test program, making it possible to carry out any type of operation using the soft-keys on the front control panel. The operator can use the straps provided to carry the unit and locate leaks using the extensible probe.

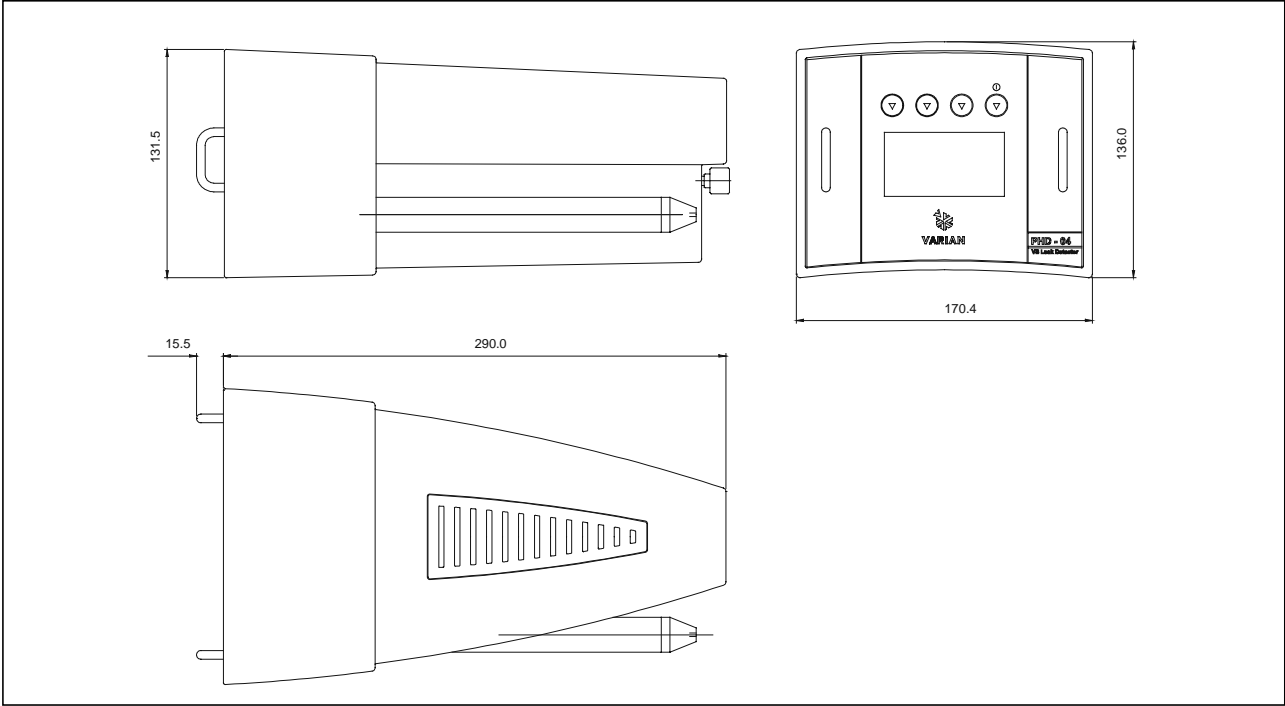

Outline

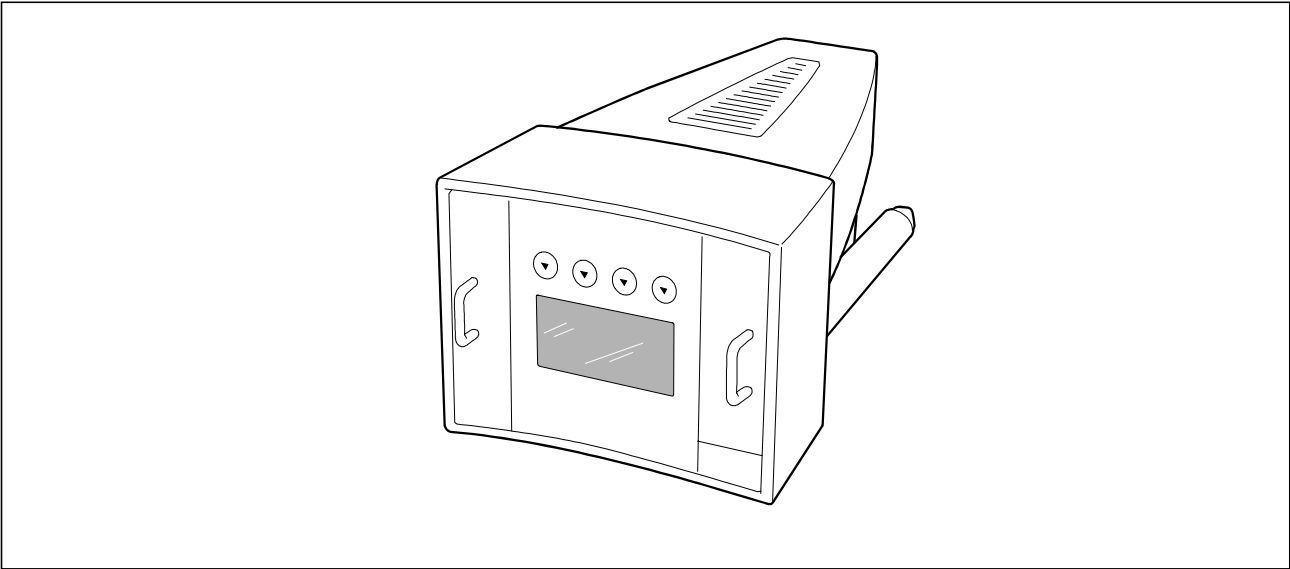

PHD-4

Theory of operation

The system to be tested is filled with a mixture of helium/air.

The probe is passed over areas considered to be critical and, via a sampling pump, the mix of gases around the areas examined is sampled and piped towards the internal sensor.

The sensor consists of a pressure detector and of a heated quartz capillary which is highly permeable to the molecules of helium, while permeability for all other atmospheric gases is negligible.

While the atmospheric gases are vented to the outside, the molecules of helium reach the pressure detector. The electric signal proportional to the partial pressure of the helium taken from the detector, is processed by the microprocessor of the central unit. This permits direct readout of the concentration of helium on the display (ref. figure below).

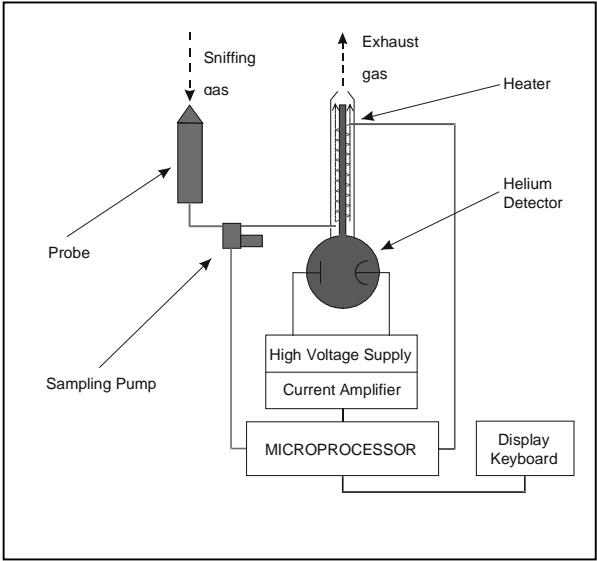

Theory of operation

BASIC UNIT DATA AND SPECIFICATION

The PHD-4 is controlled by a single microprocessor type board and includes:

- front graphic display and keypad;
- PCB with the circuits for control of sensor and the pressure measurement circuit;
- helium sensor for partial pressure measurement with integrated HV board for powering of the sensor.
- Pneumatic line consisting of the membrane pump for sampling of the environmental gases, of the twin-stage filter system and the backflow valve for protection of the sensor.
- probe, connected to the basic unit with the spiral tube that can be extended to a length of 1.5 meters.

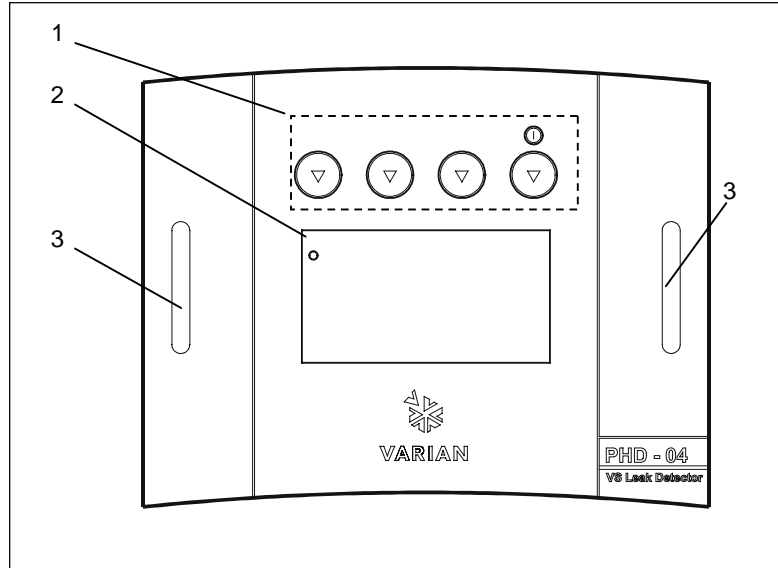

Basic unit

The figures below show a side view and the rear panel of the PHD-4.

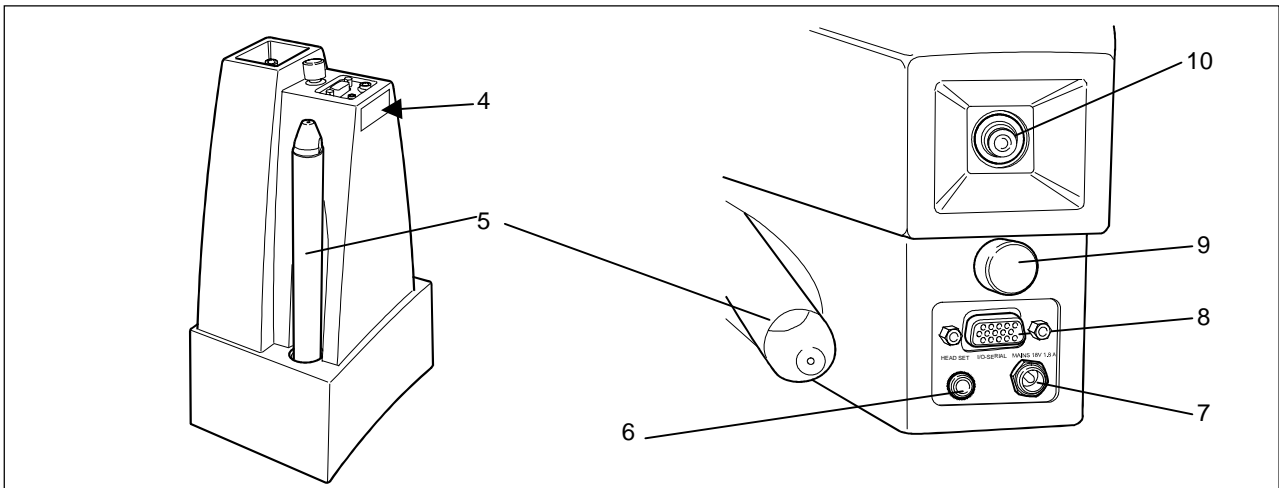

Side and rear panel of the PHD-4

- | | |
|---|--|
| <ul style="list-style-type: none"> 1- Multi-function keypad 2- Graphic display 3- Strap fixing point 4- Identification label 5- Analysis probe | <ul style="list-style-type: none"> 6- Headset connector 7- Power connector 8- RS232-I/O communication connector 9- Enclosure fast release device 10- Exhaust gas outlet |
|---|--|

**Technical characteristics of the
PHD-4 Basic Module**

Minimum detectable concentration of He	from 2 ppm (parts for million)
Minimum detectable He leak (mbar l/s)	5×10^{-6}
Minimum detectable He leak (atm cc/s)	5×10^{-6}
Minimum detectable He leak (Pa m ³ /s)	5×10^{-7}
Reaction time	2 seconds for helium according to AVS 2.1. standard
Reading drift	max. 10 ppm every 10 minutes
Measurement readout	Graphic display RS232 Analogue output
Acoustic signal	Variable frequency
Clean-up time	Average 30 seconds. Max. 5 minutes (after helium saturation).
Self-test procedure and warm-up time	3 minutes
Shut-down time	Immediate
Operating conditions - temperature - humidity	+5°C to +35 °C 90% RH (non condensing)
Jack for headset	Diameter 3.5 mm, mono or stereo headset (32 Ohm).
Transportability	Using adjustable straps
Weight	2.6kg (5.73 lb)
Dimensions mm (inches)	Width 170 (6.69) Height 136 (5.35) Depth 290 (11.4)
Power supply	in: 100-240 Vac 50/60 Hz 1 A out: 18 Vdc 2.2 A 40W
Battery operative range	4 h
Battery auto discharging	0.1% max. per day at +20 °C
Battery life	>500 charge/discharge cycles (IEC standards)
Battery charging conditions: - temperature - humidity	+10°C to +30 °C 90% (non condensing)
Installation Category	II
Pollution degree	2
Equipment Installation	Max altitude 2000 m
Compliance with	EN 55011 EN 61010-1 EN 61000-4-2 EN 61000-4-3 EN 61000-4-4 EN 61000-4-5 EN 61000-4-6 EN 61000-4-11
Relay contacts: - Voltage - Max current	24 Vac/cc 1 A (resistive load) 0,3 A (inductive load)
Input FZ/AZ: - Pin 8: positive - Pin 1: ground	Pins 8-1 closed: AZ Pins 8-1 open: FZ

PHD-4 protection function

The sensor is protected against excess flow of helium by the so-called "protection set-point" (inside the set-point icon , identified by the number "5").

This function can be used to determine the safety threshold above which the sensor is protected (see table below) activating the most suitable type of protection according to the test in progress.

Protection set-point levels

	Low sensitivity	High sensitivity
Minimum value (ppm)	200	2
Default value (ppm)	400	100
Maximum value (ppm)	600	250

Each time the protection level is exceeded during measurement, the "protection set-point" is activated and the user is alerted with a message on the display and an acoustic signal (see graphs below).

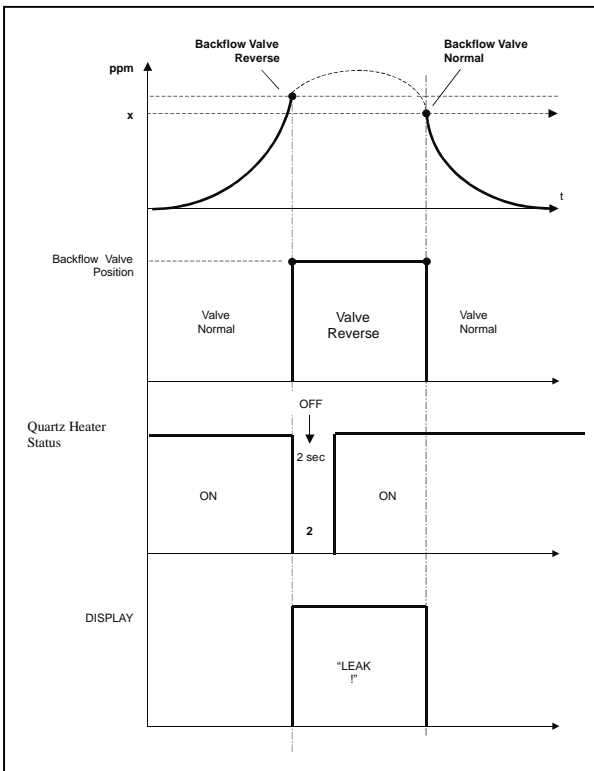

Tripping of the "protection set-point" may also trigger an active protection at one or two levels.

Protection level 1 (enabled in factory):

The backflow valve fitted in series with the sampling line is activated preventing further pumping of the gases rich in helium and, at the same time, "purging" the entire sampling line with helium-free atmospheric gases (sucked in from the exhaust point or in a helium-free environment using a dedicated line - see note).

Functioning of the backflow valve is showed in the figure below.

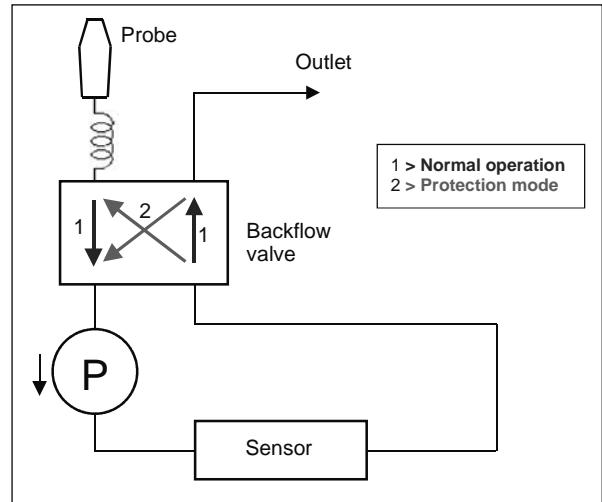

Restricting delivery of helium to the sensor, this protection extends its lifetime, also guaranteeing maximum sensitivity.

As it restricts the amount of helium conveyed to the sensor, tripping of the backflow device shortens waiting times between one measurement and the next (zeroing time).

Protection level 2:

Temporary switching off the heating element of the sensor drastically reduces the permeability of the sensor to helium, increasing the total level of protection.

NOTES:

The line dedicated to suction of the cleaning gas must have a maximum length of 5m and consists of 4x0.75mm tube.

The position of the backflow valve **A** is shown in the figure below.

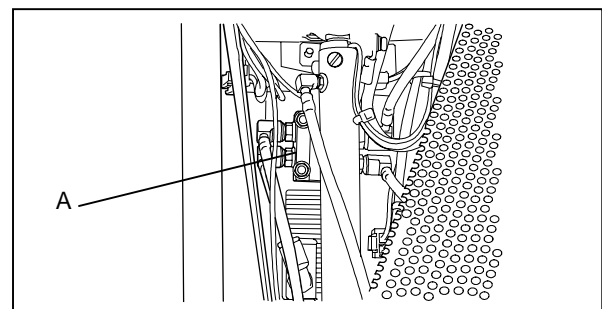

ROUTINE MAINTENANCE OF THE PHD-4

A number of important routine maintenance operations of the PHD-4 can be carried out in field.

The components on which routine maintenance operations can be carried out are the Ni-MH battery, the sampling pump and the filter system.

To access the components, remove the plastic enclosure following the instructions given below.

Removal of the enclosure

Make sure that the device has been switched off following the procedure described in the “user interface” paragraph.

1. Position the PHD-4 on a flat, rigid surface able to support its weight, as shown in the figure below.

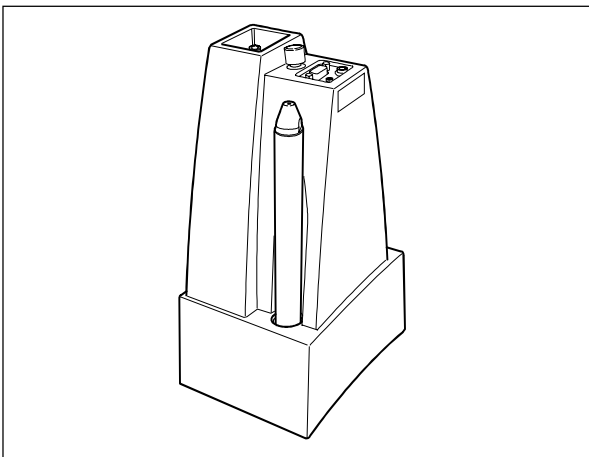

2. Press down and at the same time turn the “Quicklock” release device in a counterclockwise direction.

A click and a rotation of a ¼ of turn indicate that the enclosure has been released

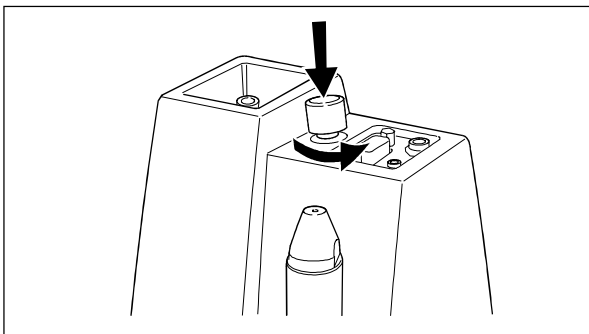

3. Remove the plastic housing uncovering the internal modules as shown in the figure.

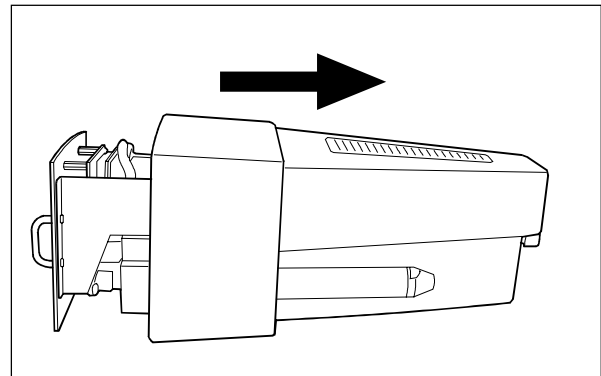

Replacement of the Ni-MH battery pack

The battery pack that powers the PHD-4 consists of 10 individual elements (Ni-HH technology) managed according to the requirements of the CPU board of the PHD-4.



WARNING!

Only the Varian 03.702609 battery can be used on the PHD-4.

Never use different battery packs not furnished by Varian S.p.A., this operation could be dangerous and cause injury to the operator and damage to the PHD-4 and to the surrounding environment.

To replace the battery pack, proceed as described below:

1. Remove the plastic enclosure as described above.
2. Position the PHD-4 inside block on a flat surface able to support its weight, placing the device so that the battery pack (located in the lower part of the module) is accessible.
3. Free the battery pack from the two strips of Velcro® **A** as shown in the figure.

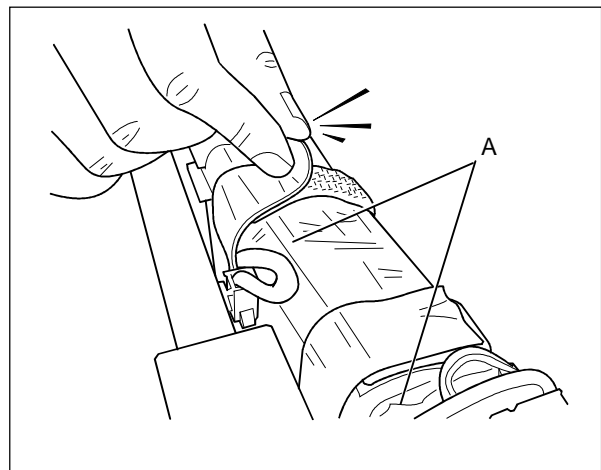

4. Slide out the four-pin electrical connector of the battery exerting a slight pressure on the lever of disconnection **B** of the connector.
5. Remove the battery pack from its housing.

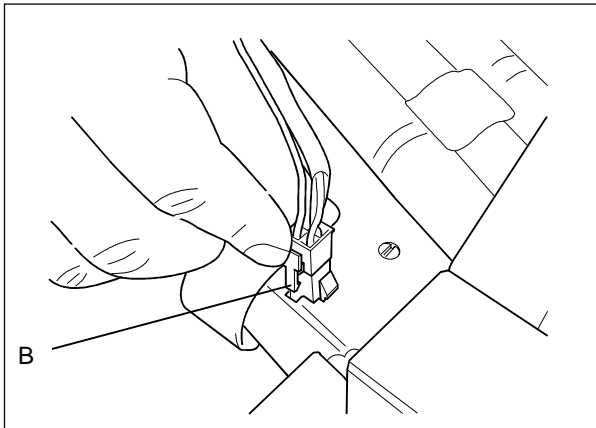

6. Position the fully charged battery pack in the housing provided.
7. Connect the four-pin electrical cable of the new battery pack to battery connector.

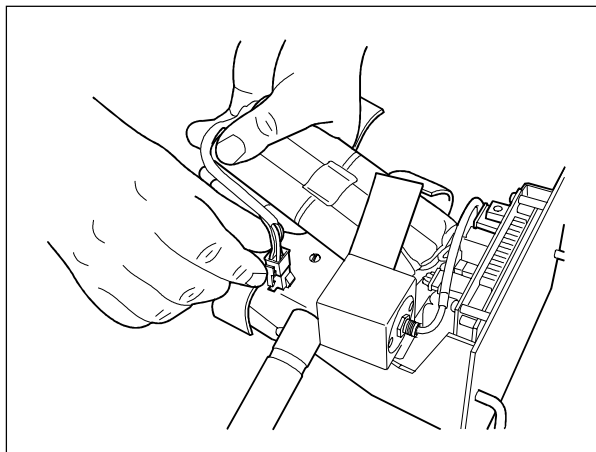

8. Reposition the edges of the strips of Velcro[®] so as to secure the battery pack in its housing.

Management of filter elements

The PHD-4 is fitted with two different filter elements: the internal glass wool filter and the sintered filter.

Replacement of the Glass wool filter

1. Remove the housing, as described above.
2. Position the inside block of the PHD-4 on a flat surface able to support its weight, positioning it so that the lower part is accessible (sampling/filter zone).
3. Holding filter **A** still, turn fitting **B** fitted on the top by ¼ of turn.

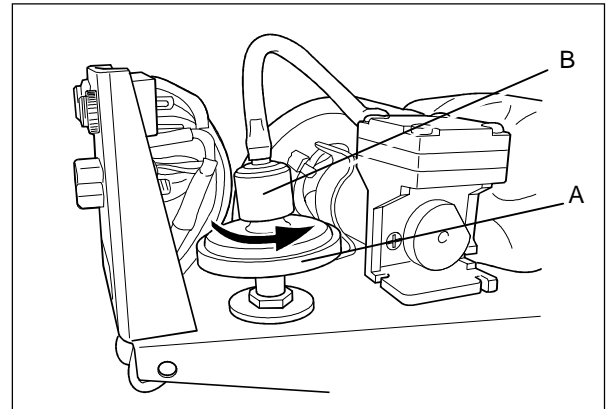

4. Remove the saturated filter **A** pulling this delicately in an upward direction.

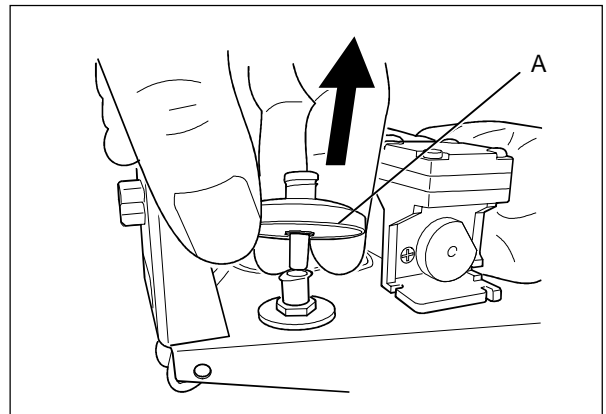

5. Exerting a slight pressure, insert a new filter.

- Position the fitting on the top of the new filter and secure it with a ¼ turn in a clockwise direction.

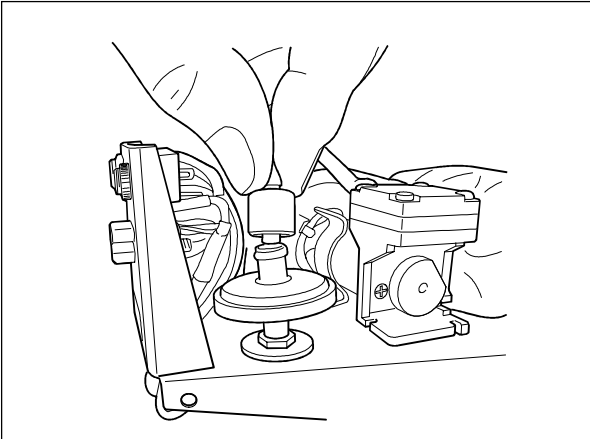

Maintenance of the sintered filter

The sintered filter is positioned on the top of the analysis probe and can be accessed removing the sampling nozzle (see figure). This filter is also accessible with the housing fitted.

- Extract probe **A** from its housing.

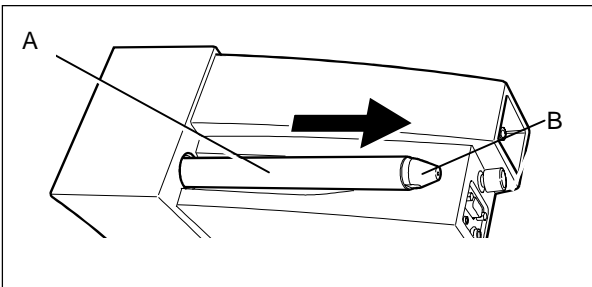

- Unscrew the sampling cone **B** on the top of the probe.

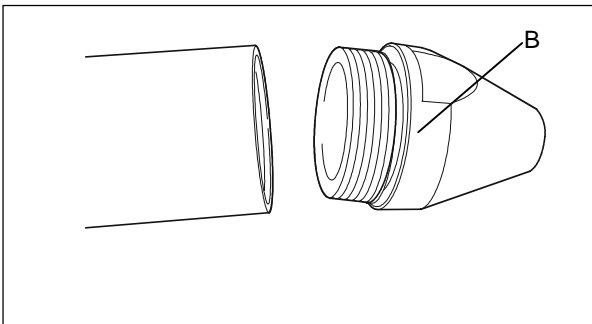

- Using a tool, unscrew the sintered filter **C** located inside the cone.

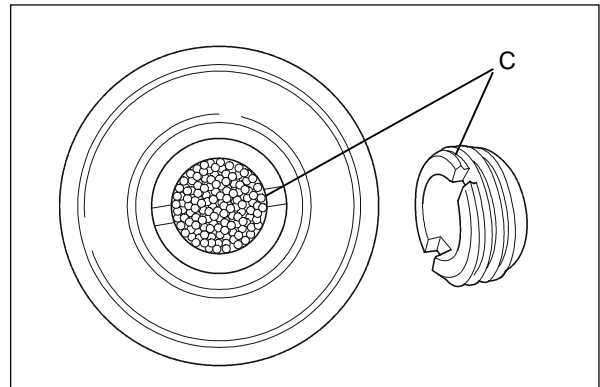

- Clean the filter with a grease remover and dry with dry compressed air. Check the connections and inspect the flexible tube for any damage.
- Retighten the sintered filter and the sampling cone

Management of sampling pump

The sampling pump is the device that makes it possible to move the gas to be analyzed from the point where a leak is suspected to the sensor inside the PHD-4. This function is afforded by the micromembrane pump which, as it sample the gas required for analysis (leak check), also allows any impurities in the gas (dust, water, oils, etc.) to pass through.

These impurities tend to accumulate inside the pumping element with a consequent gradual reduction in performance until a fault is generated.

This phenomenon is effectively contrasted by the two filter elements (see glass wool filter and sintered filter) and by the sampling auto-adjust cycle (see the chapter on "Sampling auto-adjust"); however, it is important to restrict flow of these materials inside the sampling pump.

If sampling pump performance is inefficient (this condition is notified during the initial automatic test) after use in a particularly "dirty" environment or after many hours of operation, the pumping block must be replaced.

To replace the pumping block, proceed as follows:

1. Remove the housing as described above.
2. Place the inside block of the PHD-4 on a flat surface able to support its weight, positioning the device so that the lower part (sampling/filter zone) is accessible
3. Disconnect both air tubes **A** (inlet and exhaust of the sampling pump).

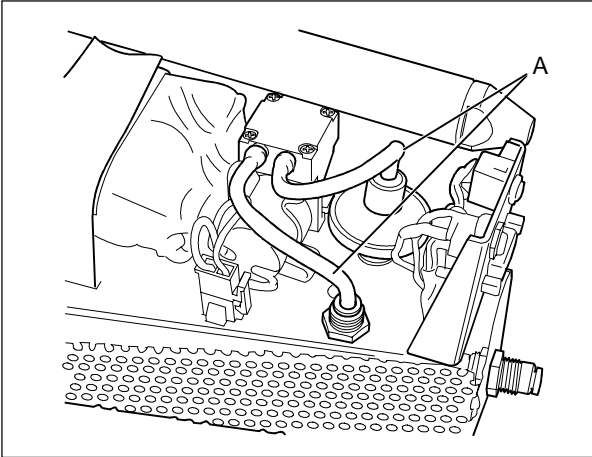

4. To remove the delivery tube, press down ring **B** so as to free the tube to be removed.

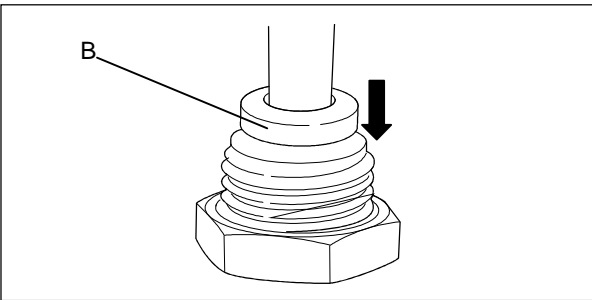

5. Disconnect the two-pin pump power supply connector **C**.

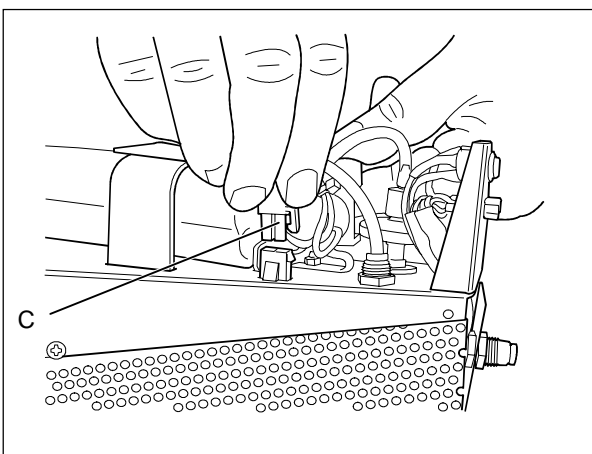

6. Exerting a slight force in an upwards direction, remove the pump **D** from its housing, releasing the retention spring **E**.

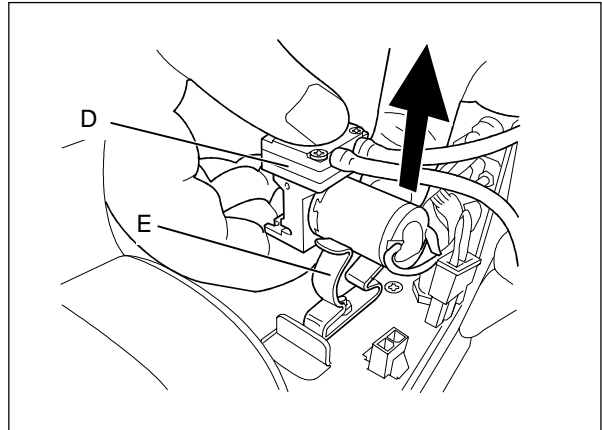

7. Reverse the process to install a new pumping element
8. Insert the new pump in retention spring **D** and then connect the power and air supply using the two non-reversible inlet and exhaust tubes.

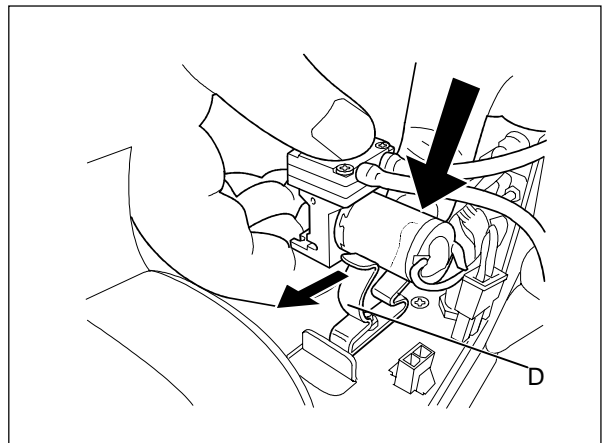

USER INTERFACE

The PHD-4 helium leak detector is designed to operate in different environments and in different applications. The many different functions necessary to operate efficiently in a wide range of different conditions are managed directly by the microprocessor on the CPU control board. The microprocessor guarantees complete control of the capabilities and of the internal components via the HID (Human Interface Device).

To start the HID and therefore to switch on the PHD-4, press and hold down for at least 3 seconds the first key **A** to the right identified by the **I** symbol.

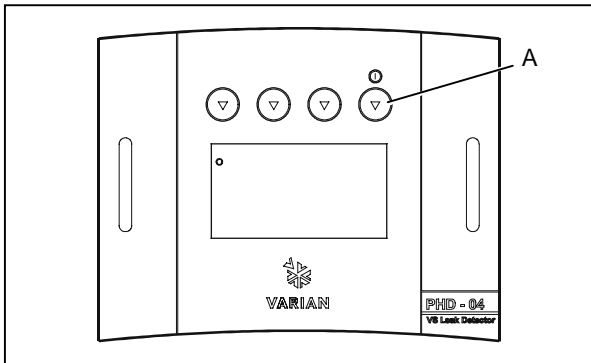

The HID starts and, after a short wait, the automatic check on the internal blocks is started (Self test):

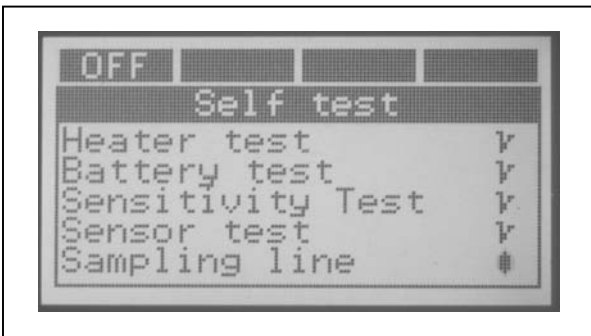

Self test

This automatic procedure is initiated by the HID each time the PHD-4 is started; this process is intended to guarantee that the measurement made with the PHD-4 is effectively valid, checking correct functioning of the components and of internal functions.

The self-test cycle comprises the following phases:

- Test on the heater
- Test on functioning of the HV power supply unit
- Battery Pack test
- Ion sensor starting test
- Test on functioning of the ion sensor
- Test on sampling effectiveness

The **“Heater Test”** function checks continuity of the platinum resistor for heating of the permeable area inside the sensor.

Positive outcome of this test guarantees that the helium sampled, together with the environmental gases, is able to penetrate inside the sensitive element and can therefore be detected.

Efficient functioning of the sensor is verified by a further three tests, the first of which is the **“HV test”**. During this test, a check is made to guarantee that a correct voltage value is present at the output of the HV power supply unit integrated in the helium sensor.

The **“Sensitivity test”** is useful for checking that the helium detection sensor is able to start and is therefore operative.

The last test carried out on the sensor is the **“Sensor test”** consisting in checking of the effective performance of the sensor.

The self-test cycle also includes a **“Battery test”** which checks that there is a sufficient residual charge for operation of the PHD-4 and the **“Sampling test”** which is useful for checking correct operation of all the components involved in gas sampling (membrane pump, sintered filter, glass wool filter, sampling line).

During running of the various tests, the items forming the list of tests are ticked with a “v” if the test is passed or combined with the “!” symbol in the case of difficulties in running the tests. If, in particular conditions, some of the tests have to be repeated, the HID highlights this conditions with the “R” (to be Repeated) symbol combined with an indication of the test concerned.

The “PS” (Power Supply) symbol is highlighted on the “Battery test” line if the battery is not present or if the fuse inside the battery has blown.

At the end of the test, a summary screen page is shown; if all the tests have been passed, the message “Self-test performed successfully” is displayed; if some of the tests have failed, a list of the problems encountered is displayed for 20 seconds before automatic shut-down of the PHD-4.

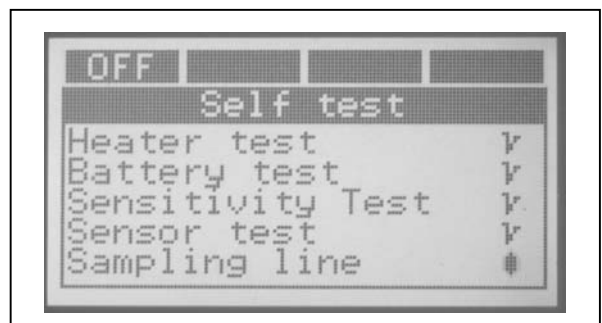

Complete Measurement screen page

The “Measurement screen page” is the operator interface provided by the HID. At PHD-4 power-on, the complete measurement screen page is displayed with which it is possible to display the all-round status of the PHD-4.

If the operator does not press any key for more than 5 seconds, the HID automatically changes data display mode activating the Large size screen page (see Large size screen).

The measurement screen page makes it possible to monitor the main operating parameters of the PHD-4, the status of the digital interface and obviously the leak rate measured, in real time.

The leak rate is displayed in the form of a bar whose length is proportional to the leak rate and also by a numeric indication in exponential format followed by the related unit of measurement.



A set of variously positioned icons highlights activation and status of the most important functions of the PHD-4.

The functions of the 4 soft-keys during the operating phases (measurement screen page) are as follows:

- Key 1: (ZERO) Fixed /automatic zero
- Key 2: (☒) Backlight ON/OFF
- Key 3: (OFF) PHD-4 OFF
- Key 4: (MENU) Link to the “Desktop menu”.

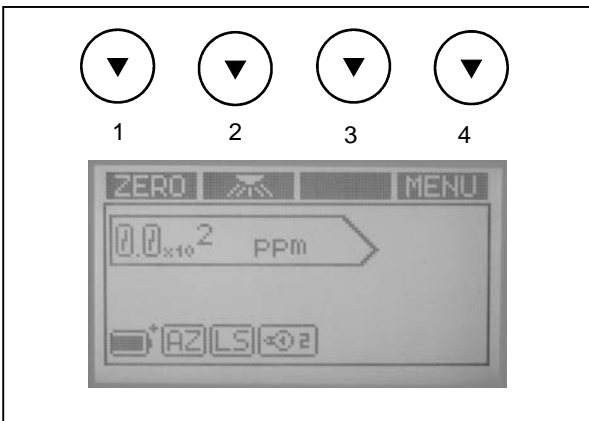

Large Size Measurement screen Page

The Large size screen page promotes excellent visibility of basic data during leak checks.

To return to normal display mode, simply press the “OFF” key or the “MENU” key. The data displayed by the Large Size measurement screen are as follows:

- Leak rate (large size type)
- Unit of measurement
- Measurement Trend (Λ) (∇) (=)
- Zero Status (Az) (Fz)



During display of the Large Size measurement screen page, it is possible to modify the zero setting (ZERO key) and to manage backlighting of the display using the key (☒).

NOTE

Large Size Measurement screen is factory set enabled. To disable this function and use the complete measurement screen un-select “LARGE SCREEN” line in SETUP menu.

Screen icons table

	Icon	Function
1		Automatic zero activated
2		Fixed zero activated
3		Low sensitivity activated
4		High sensitivity activated
5		Set-point - Normal type: enabled - Reverse type: activated
6		Back-flow valve enabled

Unit Zeroing

Two zeroing mode are available use AZ (Automatic Zero) if you operate in an environment where Helium background is variable.

NOTE

AZ mode continuously compensate the sensor reading bringing it slowly to zero. Keep it in consideration during your leak checking activity with AZ.

Use FZ (Fixed Zero) operating in an environment where background of Helium is stable.

NOTE

As soon as FZ mode is activated the current “leak rate” value is taken as a reference point and considered as zero.

Desktop Menu

Pressing the menu key from the main screen page, the HID permits access to the main menu, (Desktop menu). Using a set of icons, this menu allows graphic identification of the main functions divided into “families”. The various icons can be scrolled using the central two soft-keys (2 and 3) that are identified by the symbols “v” and “^”, selecting the icon required with key 4 (OK).

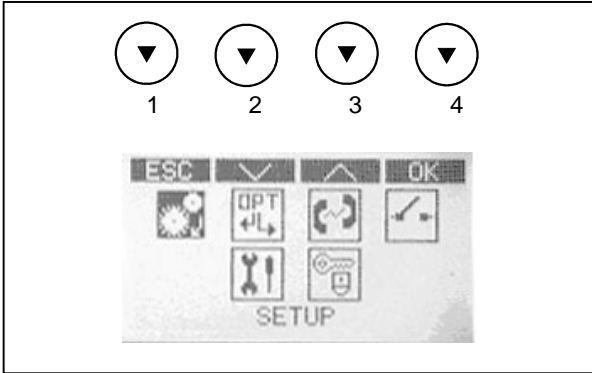

Key 1 performs the “Escape” (ESC) function; if pressed, it causes return to the measurement screen page.

The name of each icon (family) can be read in the bottom part of the display during scrolling with the “v” and “^” keys. The following submenus can be accessed from the Desktop menu.

- | | |
|-------------------|----------------|
| 1. Set-up | 4. Setpoints |
| 2. Option | 5. Maintenance |
| 3. Communications | 6. Security |

Use of the menus

Use of the menus is the same for the entire user interface and is based on the following basic rules:

Functions of the soft-keys:

Key 1 - performs the Escape function (ESC) and is used to exit the menu after viewing the data or making modifications

Key 2 – performs the function of moving the cursor down/left (where cursor means selection of the item highlighted in reverse).

Key 3 – performs the function of moving the cursor up/right (where cursor means selection of the item highlighted in reverse).

Key 4 – performs the function of confirmation (OK) if it is necessary to modify the status of a specific parameter or permits access to the submenus selected previously with the “v” and “^” keys.

PHD messages:

The HID can communicate with the operator through a set of messages of the following type

- Affirmative, highlighted inside the frame identified with the (i) mark
- Interrogative, highlighted inside the frame identified by the (?) mark.



SETUP MENU



- High Sensitivity

The High “Sensitivity” command can be used to set the most suitable degree of sensitivity for the leak detection activity in course. The degree of sensitivity set at power-on of the device is always the Low Level (LS) (“High Sensitivity” not selected). Enabling the “High Sens” command, the minimum detectable concentration changes from 100 ppm (LS) to 2 ppm (HS).

- Pump on

The “Pump on” command allows temporary disabling of intake and analysis of the gases using the probe. When “Gas sampling” is disabled, the PHD-4 is in stand-by status; the screen page displayed is the measurement page where the indication “Ready” replaces that referring to the leak rate measured.

To return to operating status, press soft-key 3 (PUMP) or return to the QUICK/Gas sampling/enable menu.

- Audio on

Disabling the “Audio on” command, it is possible to mute the acoustic signal proportional to the leak rate emitted by the PHD-4 in the operating phase.

NOTES

The acoustic signal on the rear door “Headset” is never disabled.

NOTES

The HID features two different acoustic signals to highlight different operating conditions:

- High tone for user messages
 - Medium tone for leak rate
-

- Backlight on

Disabling the “Backlight on” command, it is possible to switch off backlighting of the display.

Re-enable the “Backlight on” item of the “Set-up” menu in order to switch on display backlighting again permanently.

Backlighting of the display can be switched on for a few seconds pressing soft-key 2 in the measurement screen page, identified by the symbol (☞).

- Large screen On

The Large Screen ON command enable the automatic switching to Large Measurement screen mode.

If “Large screen on” is not selected Complete Measurement screen will operate.

- Switch Off!

At the end of the work session, the “Switch Off!” command can be used to power off the device. To prevent accidental switch-off, the HID requests confirmation before switching off the PHD-4.

A fast link to the same switch-off function is present during the measurement phase on the 3rd key of the front panel.

OPTION MENU

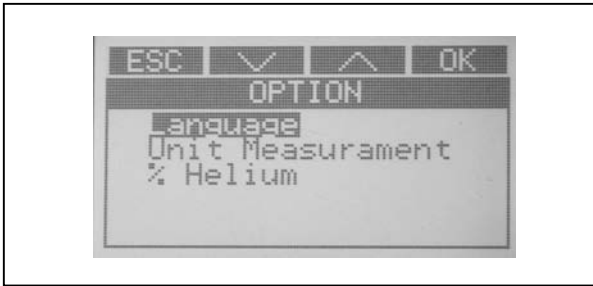

The "Option" collects together all the main settings of the PHD-4. The following items can be accessed:

Language

Using the "Language" menu, it is possible to set the language used by the Human Interface Device to communicate with the operator. There are four possible options

- English
- Italiano
- French
- Deutsch

Unit of measure

From this menu, it is possible to set the unit of measurement to be used when tracing leaks. Possible options include:

- PPM
- mbarL/sec
- cm³/sec
- cm³/min
- TorrL/sec
- PaL/sec
- Pam³/sec
- SCF/year
- Kg/h R12
- g/year R12

NOTES

The sensor fitted inside the PHD-4 is a helium concentration sensor, the unit of measurement proposed automatically by the PHD-4 is PPM (parts for million).

Use of the flow unit of measurement requires a conversion that takes into account the flow of gas sampled and the concentration of helium present in the tracer gas.

For this reason, as soon as the unit of measurement has been selected, the HID automatically opens the tracer gas selection menu (% Helium).

% Helium

The "Tracer gas" selection menu makes it possible to insert a factor that takes into account the effective quantity of helium present in the filling gas of the container under test.

Mix value display

The current setting can be displayed selecting the "Display Mix." item

Mix setting

- PPM
- %

Through the "Mix setting" item, it is possible to modify the reference to the concentration used (the factory setting is 100% He). It takes into account the actual Helium concentration in tracer gas. The value can be entered as percentage of helium in nitrogen (%) or as parts of helium per million parts of nitrogen (PPM).

NOTES

The rules for entering the values are the same to those described in the "Use of the menus" paragraph.

COMMUNICATIONS MENU



The "Communications" menu permits access to the settings of the interface board with external devices.

Remote control

- Analog Control
- RS 232 Control

Setting remote control mode, it is possible to select the reception channel of the commands from the outside (analog input / command from serial).

NOTE

Readout of PHD-4 data is always possible on both channels (RS232 or Analog port) regardless of selection of "Remote control".

NOTE

If safety set-point is enabled a "S" is showed in active set point icon on normal size measurement screen beside the number of active set-points (icon 5 in complete measurement screen icons table). As soon as the Back Flow valve is activated the icon 6 appears on complete measurement screen.

Baud rate

Using the "Baud rate" command, it is possible to modify the communication speed on the serial port between the PHD-4 and external devices. Possible settings are: 1200-2400-4800-9600-19200.

SET-POINT MENU

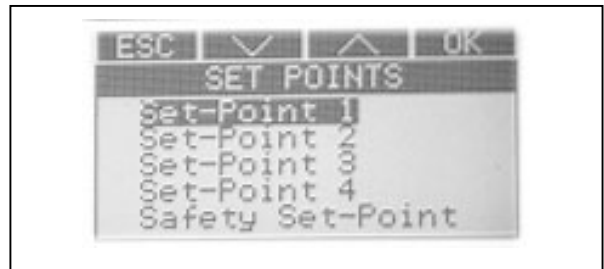

The set-point menu makes it possible to manage enabling of the five set-points of the PHD-4.

NOTES

When enabled, set points 1 – 4 manage the four relays on the PHD-4 which can be accessed via the rear connector "I/O-SERIAL".

Set-points 1,2,3,4

The set-point selected can be enabled accessing the items of the individual set-points:

- Enable

It is also possible to modify the enable value of each set-point completely independently.

NOTES

*The factory-set values are:
Set-point 1 : 10PPM
Set-point 2 : 20PPM
Set-point 3 : 30PPM
Set-point 4 : 50PPM*

Safety set-point

The fifth set-point made available by the HID is a set-point dedicated to protect the PHD-4 against excessive exposure to high concentrations of helium.

Accessing the "Safety Set-point" item, it is possible (as for set-points 1-4) to enable operation and to modify the tripping threshold in the range 2PPM-250PPM in HS and 100PPM-600PPM in LS (factory settings 100PPM in HS and 400PPM in LS).

The Safety set-point menu also contains the item:

Safety actions

- Backflow valve (factory setting: active)
- Heater OFF

This menu makes it possible to manage sensor protection actions. Protecting the sensor means restricting the flow of tracer gas (helium) to the amount strictly necessary to trace leaks.

Backflow valve – Activation of the backflow valve is part of the factory settings. This device is tripped when the threshold set is exceeded and inverts the flow sampled sampling the gas from the outlet port and then discharging this through the probe normally used for sampling.

Backflow functioning makes it possible to use the helium-free gas present at the outlet port to clean the entire pumping line and the helium exchange surface inside the sensor. The device is useful in restricting the flow of helium to the sensor. In addition to maintaining correct operation of the sensor, this device also restricts waiting times between one measurement and the next (zeroing time).

Heater OFF – Heater Switching off is a further protection in addition to the Backflow valve as it temporarily reduces the permeability of the helium exchange surface inside the sensor, restricting the flow of helium to the sensitive element and therefore guaranteeing correct operation in time.

MAINTENANCE MENU

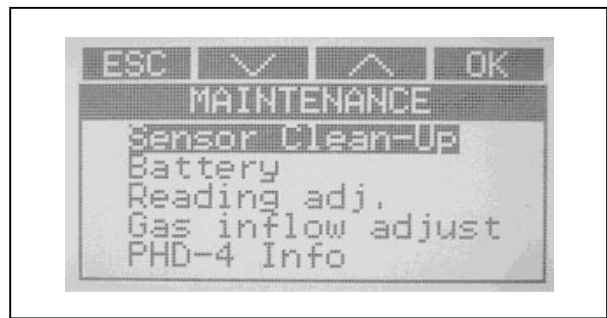

- Sensor Clean-up
- Reading adjustment
- Sampling auto adjust
- Battery pack
- PHD-4 Info

The Maintenance menu contains all the management and self.-maintenance functions of the PHD-4.

- Sensor Clean-up.

The “Clean-up” function makes it possible to eliminate any residues of Helium inside the sensor and to obtain fast, safe reset of the PHD-4.

Use the “Clean-up” function for faster zeroing after measurement of a large quantity of Helium.



WARNING!

Do not start the “Clean-up” function in environments with large quantities of helium.

- Reading adjustment

The “Reading adjustment” function makes it possible to eliminate any imprecision in reading.

Start the procedure after correctly zeroing the device in a helium-free environment.

When requested, provide the PHD-with a known mix of Helium/Nitrogen (possibly calibrated and certified) and correct readout using the “v” and “^” keys of the specific screen page.

Follow the operating instructions provided by the HID throughout the procedure.

Here following the complete reading adjustment procedure is described:

1. Press "MENU" button to enter the main menu screen.
2. Select "MAINTENANCE" icon and press "OK".
3. Select " Readind adj." line and press "OK".
4. Message "Readind adj. Do you confirm?" will appear.
5. Confirm by pressing "OK" button.
6. Message "Provide N2 or air free of Helium" will be displayed for a few seconds.
7. Provide N2 as requested and wait `until the leak rate value is "0.0 PPM (usually about 10 sec)
8. When displayed value reaches "0.0 PPM" press "OK" button.
9. Message "Provide know mix and correct reading by using "∧" and "∨" button then press "OK" will be displayed for a few seconds".
10. Provide know mixture (by using calibrated leak or commercial calibrated mixtures <100 PPM) as request and wait for stable reading.
11. Correct the reading value by using "∧" and "∨" buttons in order to reach the nominal value of the helium source, then confirm by pressing "OK" button.
12. Remove the PHD-4 probe from the helium source.
13. As soon as the unit comes back to normal operation, sniff the calibrated mixture/helium source to confirm calibration.

NOTE

Make sure the unit is in the appropriate sensitivity mode to read the helium source.

In the absence of a calibrated mix, it is possible to use the P/N Varian 969-3540 sample leak taking into account that, in this case, reading precision is approximate.

- Sampling auto adjust

The Sampling autoadjust function offsets the progressive loss of performance of the sampling line. Execution of the function is requested by the user interface every 20 h of operation but can also be started "manually" at any time ("Sampling auto adjust" command).

It is also possible not to start the procedure when requested (SKIP key) by the HID but this procedure is initiated subsequently at each start-up until it is executed.

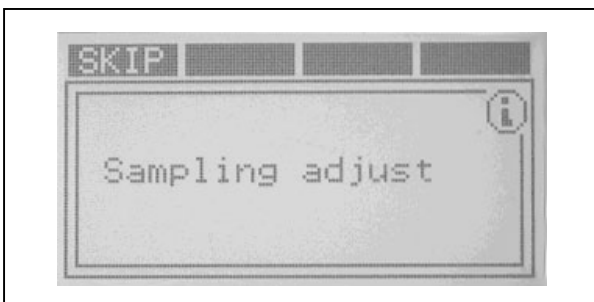

NOTES

The "Sampling auto adjust" procedure makes an indirect measurement of the flow sampled; therefore, in some cases, it may take several minutes.

Battery Pack

The "Battery" menu is the menu used to access battery pack management functions.

Battery Maintenance

The "Battery Maintenance" function makes it possible to eliminate any reductions in autonomy of the Nickel-Metal-Hydrate battery due to the phenomenon generally known as "Memory effect". Cancellation of the memory effect is obtained with fast complete discharge of the battery.

NOTES

Always start the "battery Maintenance" function after connecting the connector to the PHD-4.

The "Battery Maintenance" function causes maximum absorption of current through switching on of the heater at maximum temperature and of the sampling pump at maximum speed. During the discharge phase, the flow inversion valve is active.

NOTES

If the PHD-4 is exposed to high concentrations of Helium during discharge, the "battery Maintenance" function is interrupted in order to protect the sensor element from saturation.

Charge level

With the "Charge level" function, it is possible to know the precise percentage residual charge of the battery. With the power supply connected, no data is shown (---%).

PHD-4 Info

The "PHD-4 Info" menu provides specific information regarding the PHD-4 being used. In particular, it is possible to know: Part Number, Serial Number, Firmware release, Working time.

SECURITY MENU

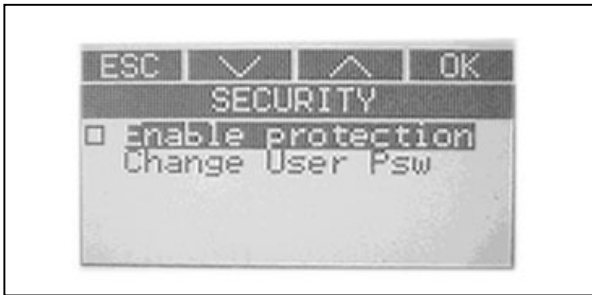

The “Locking” menu makes it possible to protect the basic parameters of the PHD-4 against modifications.

In particular, the following settings are protected: Sensitivity, Unit of measure, %Helium, Setpoint menu, Reading adjustment.

Protection can be enabled/disabled entering the password (default “00000”). The password can be modified by the user with the “Change user password” function.

Psw protection

- Enable protection
- Change User Psw

ELECTRICAL CONNECTIONS

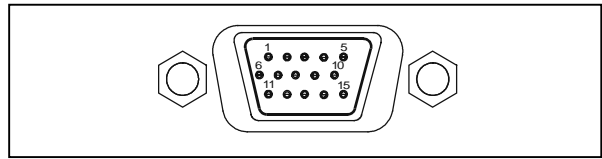

Pin number	Signal
1	Analog out (+)
2	RS232 TX
3	RS232 RX
4	Remote IN
5	RS232 GND
6	Analog out (-)
11	Relay 1 N.O.
12	Relay 2 N.O.
13	Relay 3 N.O.
14	Relay 4 N.O.
15	Relay common

ANALOG INTERFACE DESCRIPTION

The Relay 1-4 are controlled by setpoint 1-4: when the measurement value exceeds the Set Point threshold, the relative Relay is activated.

In particular Relay 4 can be controlled by the fourth set point (Set Point 4) or by PHD-4 status when the option “Ready SP ON” is activated (see Menu: Set Point / Set Point 4 / Ready SP ON).

As a factory setting the section “Ready Set Point ON” is activated.

In the first case (Relay 4 control = Set Point 4) the Relay 4 is activated (closed), when the measurement value exceeds the Set Point 4 threshold.

In the second case (Relay 4 control = PHD-4 status) the Relay is activated (closed) only if the unit is in measurement status (open if unit is in self test, reading adj., sensitivity changing, ecc.).

In the second case (Relay 4 control = Ready) the Relay 4 is activated when the PHD-4 is ready for the measurement.

As a default condition, "Relay 4 control" is set to "Ready".

The output of each relay is present on the auxiliary connector (see the figure "Electrical Connections Table").

A digital input on pin 4 controls the zero function of the PHD-4 from remote: when the input is open the FIXED ZERO mode is activated (indication FZ on the display); when the input is closed the AUTOMATIC ZERO mode is activated (indication AZ on the display).

The analog output on pins 1 and 6 provides an analog voltage proportional to the Helium concentration. Its output is from -1.25 V to +5 V according to the following values:

- in HS mode: -1,25 V = -18 ppm
+5V = 10^5 ppm
- in LS mode: -1.25 V = -1800 ppm
+4 V = 10^6 ppm

with a resolution of 0.1 V.

For more details see the following figure.

NOTE

To use the remote zero control, or analog remote control menu COMMUNICATIONS/REMOTE CONTROL has to be activated.

NOTE

The analog output voltage is always related to the measured concentration in ppm. The information does not change if a different measurement unit is selected from the front panel.

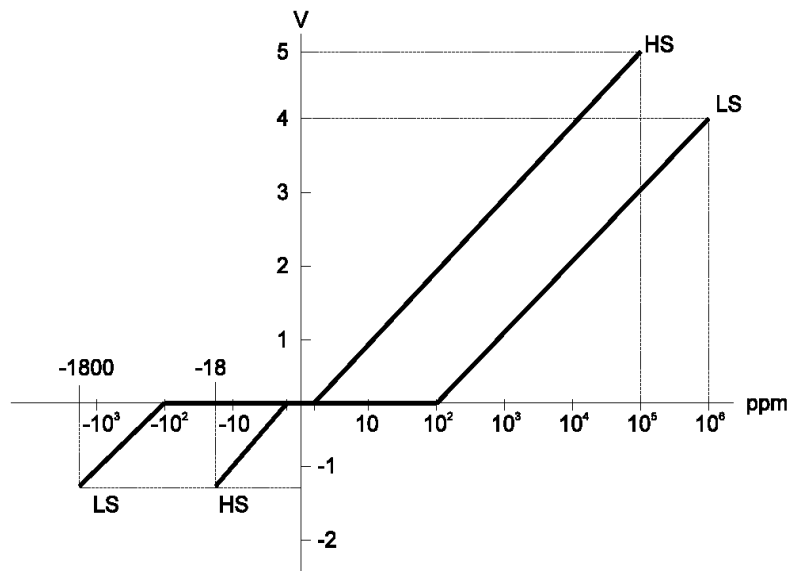

Analog Output Value Diagram

RS 232 COMMUNICATION DESCRIPTION

The RS 232 interface is available on the connector P2.

Communication Format

- 8 data bit
- no parity
- 1 stop bit
- baud rate: 1200/2400/4800/9600/19200 programmable

Communication Protocol

The communication protocol is a MASTER/SLAVE type where:

- Host = MASTER
- Controller = SLAVE

The communication is performed in the following way:

1. the host (MASTER) send a MESSAGE + CRC to the controller (SLAVE);
2. the controller answer with an ANSWER + CRC to the host.

The MESSAGE is a string with the following format:

<STX>+<ADDR>+<WIN>+<COM>+<DATA>+<ETX>+<CRC>

where:

NOTE

When a data is indicated between two quotes ('...') it means that the indicated data is the corresponding ASCII character.

- <STX> (Start of transmission) = 0x02
- <ADDR> (Unit address) = 0x80
- <WIN> (Window) = a string of 3 numeric character indicating the window number (from '000' to '999'); for the meaning of each window see the relevant paragraph.
- <COM> (Command) = 0x30 to read the window, 0x31 to write into the window
- <DATA> = an alphanumeric ASCII string with the data to be written into the window. In case of a reading command this field is not present.

The field length is variable according to the data type as per the following table:

DATA TYPE	FIELD LENGTH	VALID CHARACTERS
Logic (L)	1	'0' = OFF '1' = ON
Numeric (N)	6	'0' . . . '9' right justified with '0'
Alphanumeric (A)	10	from blank to '_' (ASCII)

- <ETX> (End of transmission) = 0x03
- <CRC> = XOR of all characters subsequent to <STX> and including the <ETX> terminator. The value is hexadecimal coded and indicated by two ASCII character.

The addressed SLAVE will respond with an ANSWER whose structure depends from the MESSAGE type.

When the MESSAGE is a reading command, the SLAVE will respond transmitting a string with the same structure of the MESSAGE.

NOTE

Some error settings are foreseen:

0x15	NACK	foreseen with Read/Write commands
0x32	UNKNOWN WINDOW	
0x33	BAD DATA TYPE	foreseen only with Write commands
0x34	OUT OF RANGE	
0x35	BAD OPERATION	

The PHD-4 can answers with the following response types:

TYPE	LENGTH	VALUE	DESCRIPTION
Logic	1 byte	-	After a read instruction of a logic window
Numeric	6 bytes	-	After a read instruction of a numeric window
Alphanumeric	10 bytes	-	After a read instruction of an alphanumeric window
ACK	1 byte	(0x6)	The command execution has been successfully completed
NACK	1 byte	(0x15)	The command execution has been failed
Unknown Window	1 byte	(0x32)	The specified window in the command is not a valid window
Data Type Error	1 byte	(0x33)	The data type specified in the command (Logic, Numeric or Alphanumeric) is not accorded with the specified Window
Out of Range	1 byte	(0x34)	The value expressed during a write command is out of the range value of the specified window
Win Disabled	1 byte	(0x35)	The specified window is Read Only or temporarily disabled (for example you can't write the Soft Start when the Pump is running)

TECHNICAL INFORMATION

Win. no.	Read/Write	Data Type	Win. Name	Description	Admitted val.
100	R/W	N	Local/Remote/Analog Selection	Selezione Local/Serial/Analog.: 0 Serial 1 Local 2 Analog	0-2
120	R/W	L	Backlight	Backlight On/Off	0-1
130	R/W	N	Language	Language selection: 0 Italiano 1 English 2 Francais 3 Deutsch	
140	R	N	Measurament Unit	Unit of measurement selection: 0 PPM 1 mbar1/s 2 cm3/s 3 cm3/min 4 TorrL/s 5 PaL/s 6 Pam3/s 7 Kg/h 8 g/y(R12) 9 g/y(R314) 10 SCF/Y	0-10
150	R/W	L	Zero Function	Auto zero / Fixed zero selection	0-1
160	R/W	N	Sensitivity Selection	Sensitivity selection: 0 LS 1 HS	0-2
170	R/W	L	Probe Function	Sampling enabling	0-1
180	R/W	L	Audio Signal	Audio signal enabling	0-1
190	R/W	L	CleanUp Function	Clean-up enabling	0-1
270	R	N	Measurament	Helium concentration measurement (PPM)	0-900'000
280	R/W	L	Set Point 1 Enable	Enabling Set Point 1	0-1
290	R/W	L	Set Point 2 Enable	Enabling Set Point 2	0-1
300	R/W	L	Set Point 3 Enable	Enabling Set Point 3	0-1
302	R	N	Working Time	Total lifetime (h)	0-100'000
310	R/W	L	Set Point 4 Enable	Enabling Set Point 4	0-1
315	R/W	L	Safety Set Point Enable	Enabling Safety Set Point	0-1
320	R	A	PHD P/N	Part Number of PHD	-
322	R	A	PHD S/N	Serial Number of PHD	-
324	R	A	PHD Modific. Level	upgrade level of the PHD	-
330	R/W	L	Valve Enable	Backflow valve enabling	0-1
340	R/W	L	Heater enable	Heater OFF enabling	0-1
350	R/W	N	Set Point 1 Value	Set point 1 threshold (PPM)	0-900'000
360	R/W	N	Set Point 2 Value	Set point 2 threshold (PPM)	0-900'000
370	R/W	N	Set Point 3 Value	Set point 3 threshold (PPM)	0-900'000
380	R/W	N	Set Point 4 Value	Set point 4 threshold (PPM)	0-900'000
390	R/W	N	Safety Set Point Value	Set point Safety threshold (PPM)	0-900'000

TECHNICAL INFORMATION

Win. no.	Read/Write	Data Type	Win. Name	Description	Admitted val.
406	R/W	A	Program Listing	Indicates Program Listing code and release	-
407	R/W	A	Parameter Listing	Indicates Parameter Listing code and release	-
410	R/W	N	Battery Charge Level	Battery pack residual charge (%)	0-100
450	R/W	N	BaudRate	Defines serial communication baud rate: 0 1200 bit/s 1 2400 bit/s 2 4800 bit/s 3 9600 bit/s 4 19200 bit/s	0-4
460	R/W	N	Auto-test alarms	It defines the Allarm status: 0 OK 1 Heater fail 2 Sampling line fail 3 Battery fail 4 Sensitivity fail	0-4
570	R/W	L	PHD-4 ON/OFF	It switch PHD-4 ON and OFF	0 (OFF) 1 (ON)

TROUBLESHOOTING

Here following some troubleshooting tables are reported. Refer to the troubleshooting tables to locate and understand fails of your PHD-4. Troubleshooting tables give you information about procedures available to fix the fail occurred to PHD-4 and advices for a good use of PHD-4 and a consequent long operative time without fails.

In coloumn "Trouble" are showed issues that could affect your PHD-4.

In coloumn "Answer" on right side possible reasons of fail and solutions (if present) are listed.

Trouble	Answer
Sampling line fault	
Sensitivity test fault	
Sensor test fault	
Unstable reading	
Reading drift	
Low sampled flow	
Short operative range	

Troubleshooting table 1

Trouble	Answer
Sampling line fault	<p>Due to clogging of line or fail of diaphragm pump.</p> <ol style="list-style-type: none"> 1 Check probe line (pipe) 2 Replace glass-wool filter 3 Clean sintered filter 4 Replace Sampling pump <p>Start Sampled flow auto-adjust</p>

Troubleshooting table 2

Trouble	Answer
Sensitivity test fault	<p>Due to difficulties in sensor trigger (sensor too clean)</p> <p>1 Spray few He near the probe during “Self test” procedure</p>

Troubleshooting table 3

Trouble	Answer
Sensor test fault	<p>Due to saturation of the sensor (High ion current) or large amount of He trapped in the capillary quartz.</p> <p>1 Provide N2 or air free of He</p> <p>2 Repeat many times “Self-test” procedure.</p> <p>As a general rule...</p> <p>Avoid sniffing large amount of He (concentration, pressure)</p> <p>Use backflow valve protection</p> <p>Start checking in LS</p>

Troubleshooting table 4

Trouble	Answer
Unstable reading/Reading Drift	<p>Due to saturated sensor (spikes) or high room temperature (drift)</p> <p>Operate with environmental temperature between 5°C and 35°C - 90%HR</p>

Troubleshooting table 5

Trouble	Answer
Low sampled slow	Due to clogging of line Check probe line (pipe) Replace glass-wool filter Clean sintered filter Start Sampled flow auto-adjust in addition to periodical start (20h)

Troubleshooting table 6

Trouble	Answer
Short operative range	Due to Ni-MH battery pack memory effect 1 Replace battery pack (if service life >500 cycles) ‘ 2 Start “Battery care” function

ACCESSORIES AND SPARE PARTS

DESCRIPTION	PART NUMBER
Probe Set	9693515
Capillary leak with refillable reservoir and gauge	9693540
Probe with 10 meter (30') maximum Sampling Line	9693525
Telescopic Extension Probe	9693520
Spare battery	SR 03.702609
Transformer/Battery Charger (110 – 220 V)	SR 03.702888
Sampling Pump with Fittings	SR 03.702513
Probe with Sampling Line	SR 03.702538
Tip probe filter	SR 28.900012-01
Internal filter (Kit of 5 units)	SR 03.702959
Carrying Strap	SR 03.702791
15-pin I/O connector	SR 03.702794
Travel Case	SR 03.702890