

# Fluke IR Window field of view

These Field of View (FOV) calculations are based on best practices used during infrared inspections and serve as a guide when choosing IR Window sizes and locations.

Please note that the illustrations represent achievable FOV at a distance of 30.48 cm (12 in) to target. Additional FOV calculations at various distances to target are given in the tables below. Actual FOV can vary based upon equipment layout (phase barriers, internal compartments, etc.). Be sure to verify IR Window position before drilling holes for installation.

For illustration purposes, only horizontal FOV is shown. Adjusting the position of the thermal imager allows the overall FOV to be achieved in all directions—360 degrees.

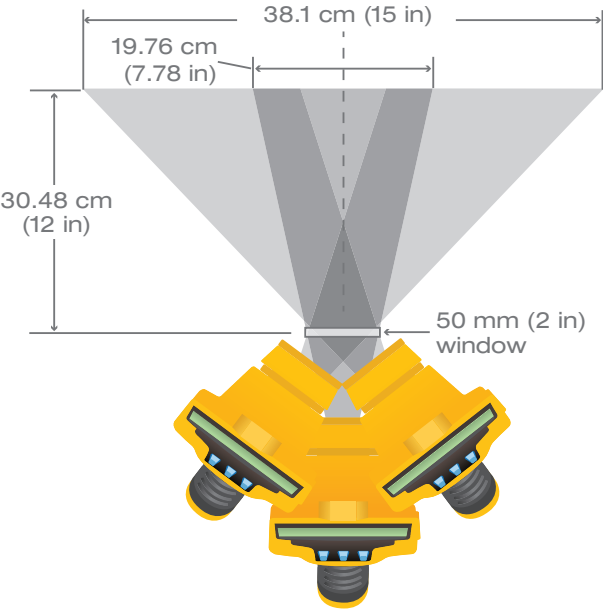
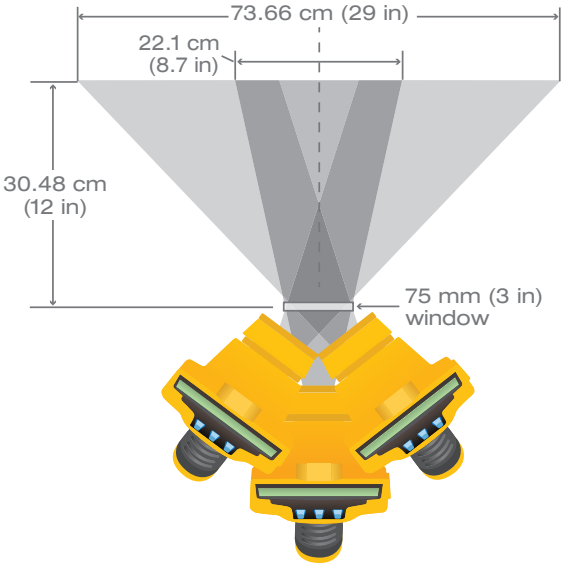
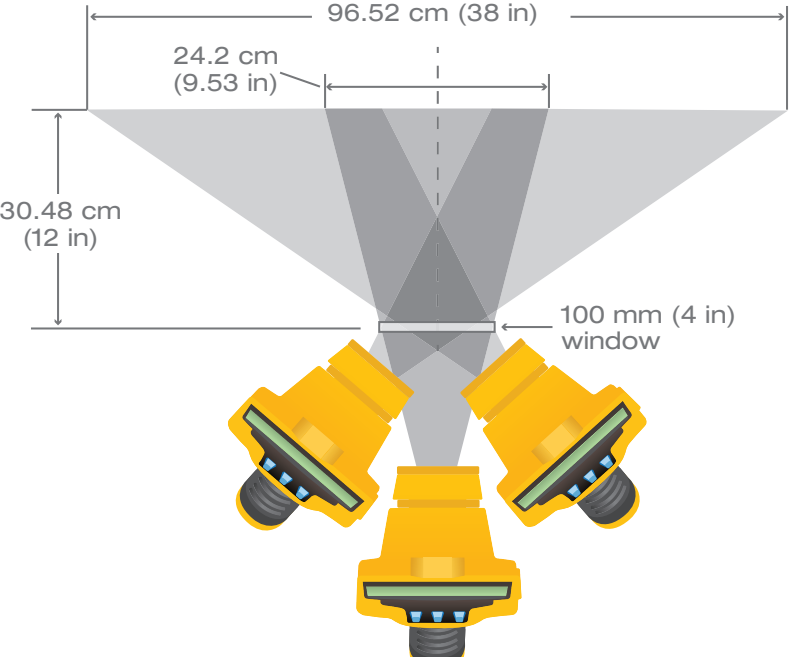

IR window size	Distance to target			
	15.24 cm (6 in)	30.48 cm (12 in)	45.72 cm (18 in)	60.96 cm (24 in)
<b>100 mm (4 inch)</b>	53.34 cm (21 in)	<b>96.52 cm (38 in)</b>	139.7 cm (55 in)	182.88 cm (72 in)
<b>75 mm (3 inch)</b>	40.64 cm (16 in)	73.66 cm (29 in)	109.22 cm (43 in)	142.24 cm (56 in)
<b>50 mm (2 inch)</b>	20.32 cm (8 in)	38.1 cm (15 in)	53.34 cm (21 in)	68.58 cm (27 in)

All calculations based on Fluke Ti32 Thermal Imager with standard lens (23° x 17°).

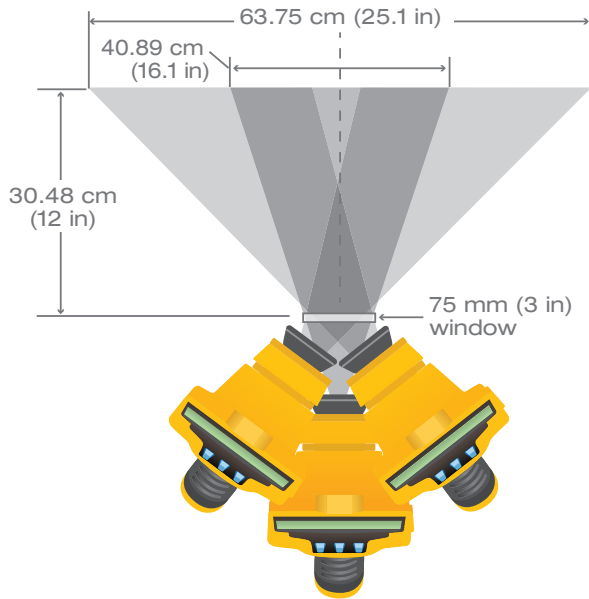

### Wide-angle lenses

Compared to a standard lens (23° x 17°) a wide-angle lens (46° x 34°) offers a larger FOV when positioned perpendicular to the IR Window, as shown. However, the size of the wide-angle lens itself limits the ability to position the thermal imager at much of an angle. This means that the achievable FOV with a wide-angle lens, obtained by angling the thermal imager, is actually less than that of the standard lens. This can vary based on camera model.

Calculations based on Fluke Ti32 with wide-angle lens (46° x 34°)

#### 75 mm (3 in) wide-angle lenses

Distance to target	30.48 cm (12 in)
FOV	63.75 cm (25.1 in)

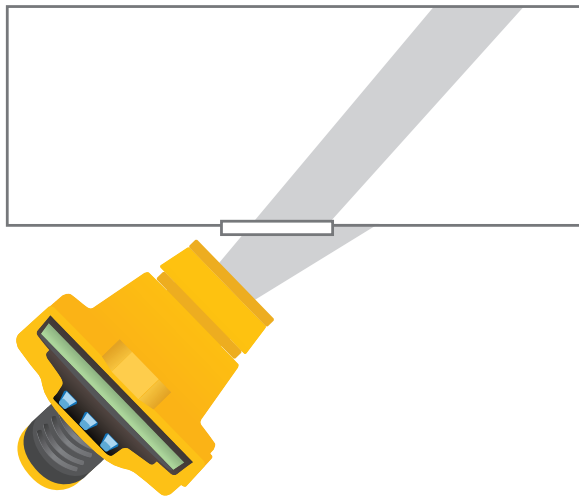

### Extreme angles

A maximum attainable FOV (roughly 6xD) can be achieved by positioning a thermal imager at extreme angles. These angles require that the view through the thermal imager include seeing both through the IR Window (inside the enclosure) and beyond the IR Window (outside the enclosure). Such positioning does not expose the entire surface of the camera lens to the target being measured and when combined with the steep viewing angle, slightly less accurate results should be expected.

## Alpine Components

Telephone: [01424 437000](tel:01424437000) E-mail: [info@alpine-components.co.uk](mailto:info@alpine-components.co.uk)

Web: [www.alpine-components.co.uk](http://www.alpine-components.co.uk) Fax: [01424 722502](tel:01424722502)